

POWER PALLET **2000**



A complete drive package that can be installed onto your manual jack, converting it into a very powerful, yet ultra-compact, motorized jack.

OVERVIEW OF FEATURES

POWERHANDLING
SMARTER. SMALLER. STRONGER.

**A UNIQUE, MULTI-PATENTED DESIGN
THAT DELIVERS SIGNIFICANT ADVANTAGES**

- INCREDIBLY COMPACT (Page 3)
- UNMATCHED MANOEUVRABILITY (Page 4)
- NEVER DOWN (Pages 5 & 6)
- SURPRISINGLY POWERFUL (Page 7)
- SPEED & CONTROL (Page 8)

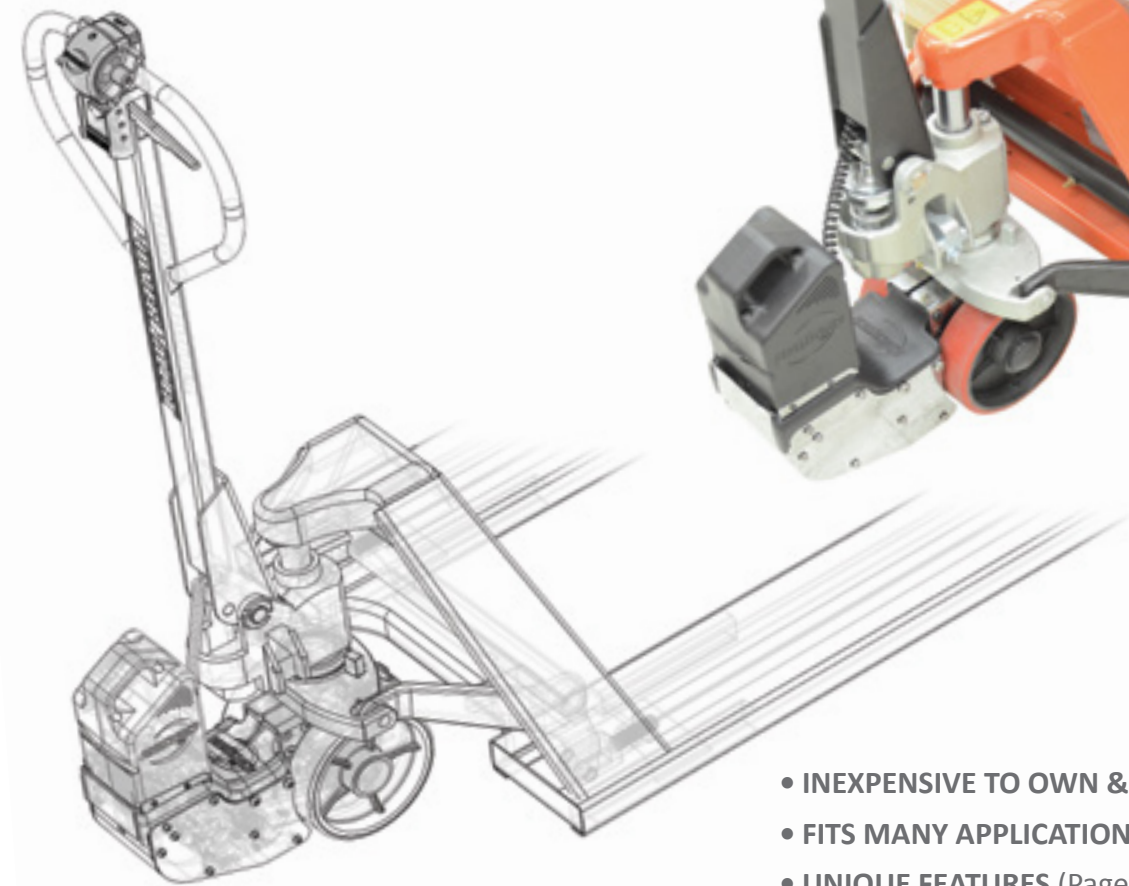

- INEXPENSIVE TO OWN & MAINTAIN (Pages 9 & 10)
- FITS MANY APPLICATIONS (Pages 11 & 12)
- UNIQUE FEATURES (Page 13)
- TRULY INNOVATIVE (Page 14)



TURNING RADIUS

With a turning radius the same as for a manual jack, there is nothing more compact or user friendly for manoeuvring heavy loads in tight spaces.

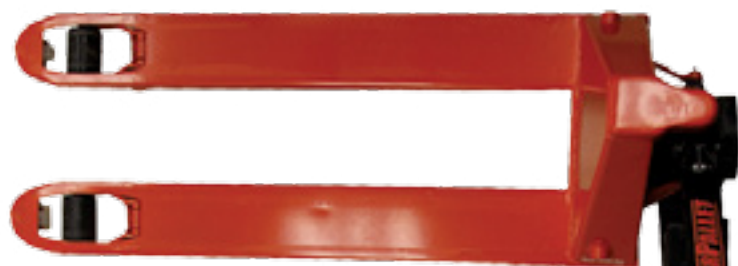

GREAT 'OPERATOR VISIBILITY'

Plus, the ultra-compact size of the attached drive unit improves operator visibility of both the load being moved and the surrounding work area.

This gives the operator a much better sense of the load he's moving, allowing him to work more confidently and quickly.

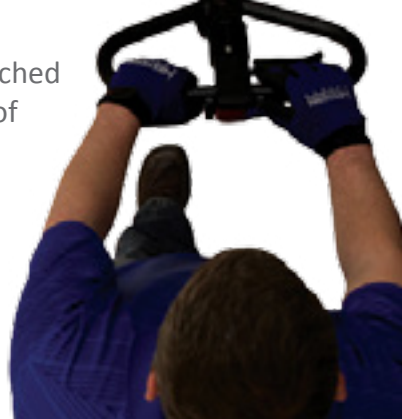

'TRUCK MODE'

A push of the mode button changes the unit from "warehouse mode" (green light) to "truck mode" (orange light)... designed for back of truck operation. In this mode the unit can be operated with the handle vertical and max speed is reduced.

EFFORTLESS TURNING

The patented design of the PowerPallet 2000 locates the drive wheel within a spring loaded drive arm. A max of 350lbs is born by the drive wheel (*enough load transfer for reliable traction*), while all additional weight is born by the steering wheels of the jack.

This results in less effort manoeuvring at low speeds.

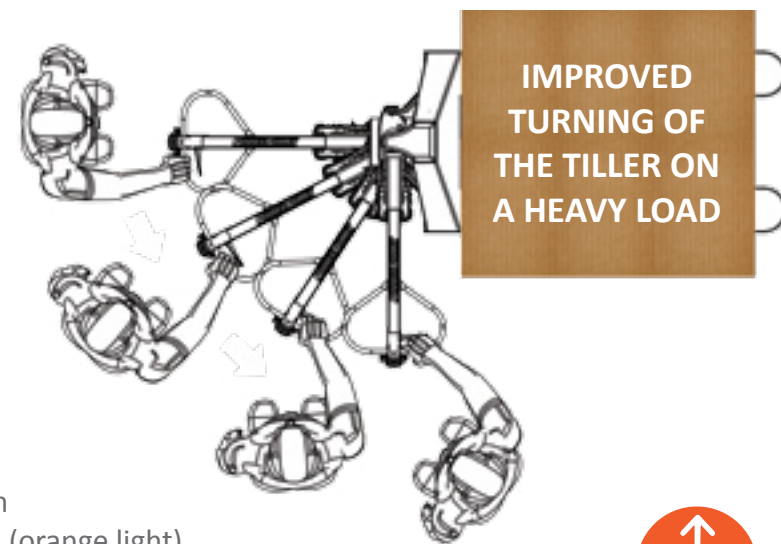

When a walkie is down... that's it. Whether it is a dead battery or a mechanical issue, you won't be using that unit until the problem is corrected.

But with the PowerPallet 2000 solution, you're NEVER down!

(You can change the battery or just revert back to a manual jack).

QUICK-CHANGE BATTERIES

The PowerPallet 2000 uses small, light, high performance NiMH battery packs that charge off-machine with a compact quick charger. As such, this machine never needs to be "down" to be recharged. The operator can switch out a used battery for a charged one in just seconds and continue running uninterrupted.

In contrast, conventional motorized trucks will typically use old technology such as, lead-acid based batteries that are larger, heavier and need more recharging time, which limits flexibility. *(And the environmental impact?... 200 lbs of Lead-Acid vs. 9 lbs NiMH!)*

Up to 4 Quick-Chargers can be "daisy chained" together from a standard 110V power outlet.



Change out a depleted battery for a recharged one in less than 5 sec's.



SWITCH TO 'MANUAL MODE'

Q) Are you "down" (as with a typical powered truck)? Your battery goes flat mid-move and you don't have another available.

A) Only for the 2 seconds it takes to hit the 'MODE' button to switch to free-wheeling 'manual mode'. This allows the motor to spin freely and therefore operate the jack manually.

DISENGAGE THE DRIVE ENTIRELY

Q) Are you "down" now? The problem is more serious and the entire drive unit seizes up.

A) No. The operator can easily and quickly tilt the pallet jack and remove the red drive-arm compression spring. The two remaining extension springs pull the drive arm (and drive wheel) up and out of contact with the ground.



PowerHandling has over 15 years of experience building ultra-compact, high torque machines for industrial applications. From moving 10,000lb paper rolls to 200,000lb commercial aircraft and even a 650,000lb valve at a hydroelectric plant install... all using our high-torque 'barely larger than a shoe box' battery operated movers. Now we have brought this experience to the pallet moving industry with our 3,5000lb rated, POWERPALLET 2000.

CONTROLLING THE POWER...

The PowerPallet 2000's operator interface is intuitive and easy-to-use. It can mount to most pallet jack handles, and when it can't, a new handle can usually be fitted. The throttle provides precise speed control from 0 to 3.7 mph (and can be set to a lower speed if required).

Braking is automatic on throttle release (dynamic braking) and is adjustable for gradual or immediate stopping. The angle of the handle also influences braking and speed control in all modes. (see below)



In Warehouse/Fast-mode the brake zones are at the **TOP** of the handle arc (vertical) and **BOTTOM** (horizontal) positions.

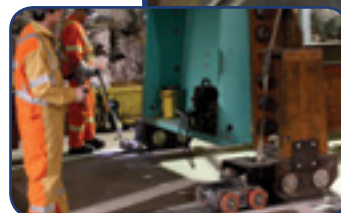
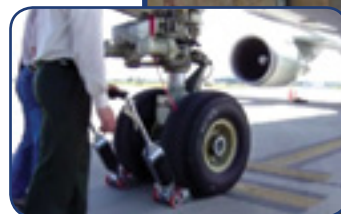
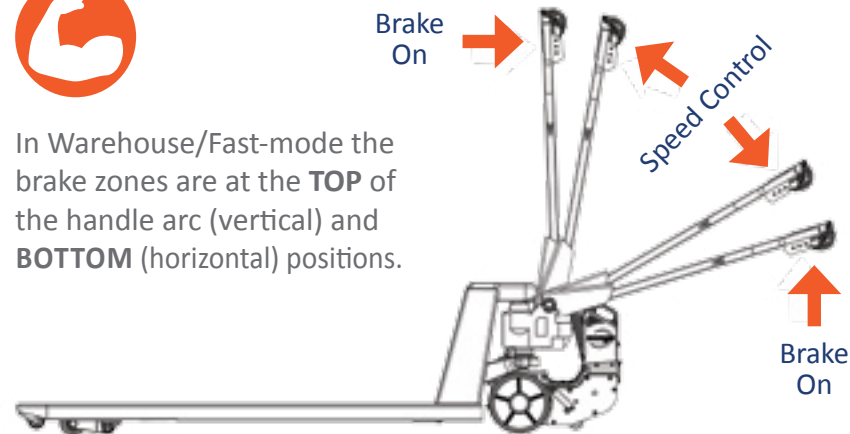

...THROUGH ADVANCED TECHNOLOGY

Intelligent use of technology can bring a more intuitive user experience while also improving safety. Accelerometers, located in both the throttle and base unit provide positional, directional and acceleration data every 1/100th of a sec. Constant analysis of those values means the PPR-2000 knows its location, orientation and velocity at any moment in time.

Another technology feature is the integrated USB port. Used for updating software, but also tailoring various parameters and functions and providing a great feature - "keyed operation" This turns USB drives into tailored "keys" that modify the PowerPallet's operation for each specific user, or lock out users without a key.

The PowerPallet 2000's brush-less DC motor is precisely controlled, providing features like "controlled hill descent" which improves usability when slopes need to be navigated. Another feature is the auto power-off. In "USB Key Required" mode its after 15 sec's and in "No USB Required" mode its after 100 sec's. (Hit the belly-button to restart).

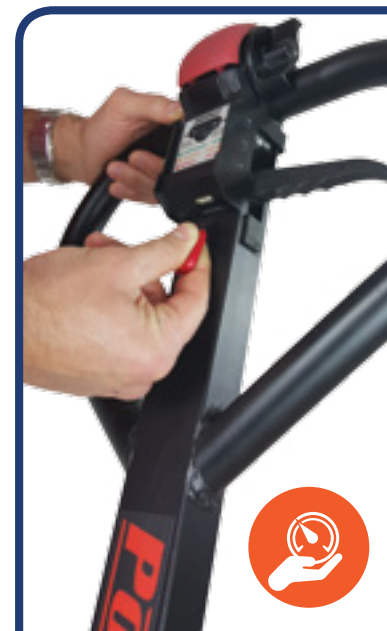

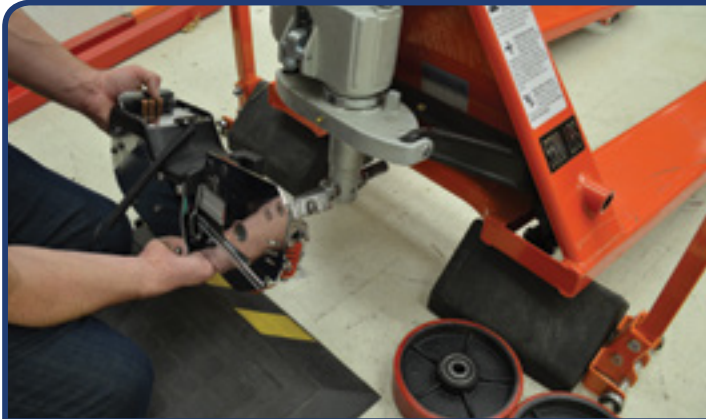

INSTALL ON A JACK IN LESS THAN 30 MINS

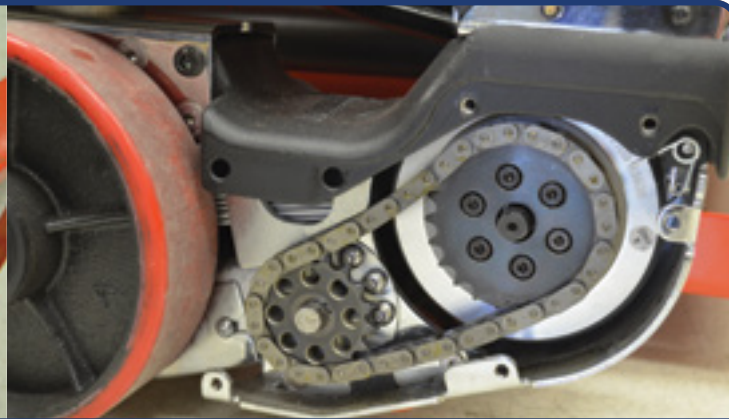

CHANGE A DRIVE CHAIN IN LESS THAN 10 MINS



ADD CHAIN LUBRICANT IN LESS THAN 5 MINS



CHANGE THE DRIVE WHEEL LESS THAN 10 MINS

THE BOTTOM LINE

There's no arguing the facts...

A low acquisition cost and even lower operating cost makes a big difference to your bottom line! A complete PowerPallet 2000 package, including the drive unit, battery pack, mounting plates and charger is nearly half the cost of a standard "walkie".

Additionally, although easy to install on most, major brand manual pallet jacks, PowerHandling can also ship pre-installed onto a high quality new jack, with 'Quick-Lift' included as standard for a minimal additional cost.

SIMPLE TO INSTALL

Installs in 10 simple steps with no special tools required and helpful instructional video's on YouTube. Estimated installation time is 30 minutes for the first time and 15 minutes with previous experience.

SIMPLE TO PERSONALIZE

The PPR 2000 has many user adjustable features and functions to meet the user and application requirements.

SIMPLE TO MAINTAIN

Virtually maintenance free with replacement parts priced economically (*example: Drive Wheel... \$28*). A 1-Year Limited Warranty is included on the Drive System, Throttle Assembly & Charger.



TRUCKING / DELIVERIES



Most trucking companies have manual jacks in the back of their trailers for manoeuvring pallets. For this task the PPR-2000 is ideal, being ultra-compact and light yet very powerful. Switch into "Truck Mode" and the speed slows, torque increases and the unit will operate with the handle fully upright. Even the heaviest pallet loads can be easily manoeuvred... regardless of the size or strength of the operator.

MANUFACTURING



Manufacturers may not be continually moving loads, but they need the power and convenience of a compact powered pallet truck to be always available... right when they need it. Whether its moving heavy WIP loads between work stations or loading and unloading on the dock, having a PPR-2000 that can go wherever a manual jack can, but with power and speed, is a huge benefit.

SMALL FORMAT RETAIL



The PPR-2000 is the perfect solution for small format retail stores. Power when you need it for the heavier pallets (beverages, tinned food, salt, etc.) with the torque to traverse uneven thresholds or ramps. With typically narrow aisles and a low daily usage, electric walkies may not be the best fit. Plus, the PPR-2000 can do double-duty back of store on the loading dock!

LARGE FORMAT RETAIL / BIG BOX STORES

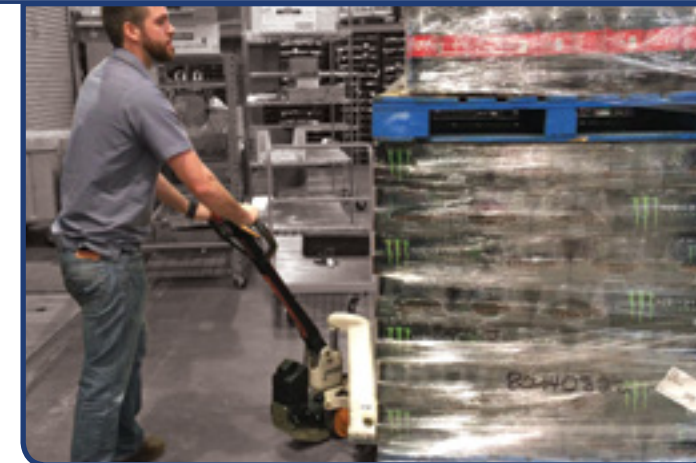

In larger retail locations and 'big box' stores, having PPR-2000 units staged around the store reduces the amount of time employees search and retrieve forklifts, improving productivity and ergonomics. The 'USB key to operate' feature is ideal here, plus the PPR-2000 can be used in powered or manual mode (depending on store policies and conditions).

SEPARATE THE TECHNOLOGY FROM THE COMMODITY

The PowerPallet 2000 Drive Unit has been designed so that it is shielded from damage as much as possible. The patented 'compliant drive arm' design acts like a suspension to isolate the motor and electronics from impact and vibration. The concept is to separate the 'technology' (the PowerPallet Drive Unit) from the 'commodity' (the manual pallet jack) and thereby improve the overall return on investment.

Pallet jacks are rarely maintained nowadays. With the cost of labor it is more cost effective to just replace the entire jack once the forks are damaged, hydraulics begin to fail or even when the wheels have worn. With a removable drive unit just remove the PPR-2000 and reinstall it on a new jack to further the value of that original investment.



ALL JACKS CAN BE CREATED 'EQUAL'

A mixed fleet of jacks... different models, ages and conditions... can all become equal once retrofitted with PowerPallet drive units. This provides users an identical operator interface. What jack the PowerPallet is attached to makes less of a difference now and whichever unit is most handy works – providing the same power and speed with a near identical user experience.



POWERPALLET... IT SIMPLY WORKS!

This machine is not just another walkie. It is a revolution in thinking in ergonomic and cost-effective pallet moving.

Simply put, the PowerPallet 2000 can greatly improve both the productivity and ergonomics of your operation, while still maintaining all the flexibility afforded by a manual jack.

The compact, powerful and feature-rich PPR-2000 provides an excellent user experience, while also looking exceptionally good on your bottom line.

TRY A POWERPALLET 2000 TODAY!



COMPACT



MANOEVRABLE



QUICK CHARGE



ECO-FRIENDLY



SPEED CONTROL



POWERFUL



LOW MAINTENANCE



LOW COST



INNOVATIVE



ERGONOMIC



RELIABLE

NORTH, CENTRAL, SOUTH AMERICA AND ASIA-PACIFIC REGION

Corporate Office (U.S.A)

3223 N. Market St, Spokane, WA 99207

Production & Customer Service (U.S.A)

1420 E. 3rd St, Post Falls, ID 83854

sales@powerhandling.com

www.powerhandling.com

1.888.377.6937

EUROPE, MIDDLE EAST, AFRICA AND BRAZIL

Engineering, Sales & Service (PORTUGAL)

Rua Pé de Mouro, Centro Empresarial

Lusoworld II, Armazém 35, Linhó

2710-335 Sintra, Portugal

sales-eu@powerhandling.com

www.powerhandling.com

+351 219 249 835



Follow us on our You-tube channel to view our product videos.