

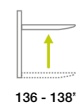

# GX12

This robust and reliable stacker features adjustable base leg design that makes it the ideal solution for working in confined spaces. It is equipped with powerful semi-traction batteries that allow longer endurance and greater number of charging cycles. Its Duplex mast allows a lifting capacity with Free Lift version available. The reduced width, the lateral driving and the wide mast positioning assure great maneuverability, stability and visibility. The built-in battery and charger with integrated cable and plug make the GX a plug and play unit.

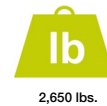

## PROPERTIES / ADVANTAGES

### TILLER EVOLUTION



Fully integrated ergonomic tiller made in technopolymer offering comfortable grip. Fingertip throttle and proportional fork controls, safety push button, horn, turtle button, hour-meter, battery status indicator as standard equipment.

### MANEUVERABILITY



The overall width of the GX allows the unit to work in narrow spaces and corridors providing unmatched manoeuvrability at a controlled speed and precise control.

### COVER



Strong ABS cover with storage compartments on top, easily removable to speed up maintenance operations. The bottom access opening allows an immediate disassembly of motor wheel, portal and tiller without lifting the machine. A plug with cable is available for an easy battery charging.

### BATTERY PACK



The separate battery compartment is the housing of AGM batteries. Such batteries are lightweight and inexpensive allowing up to 3 hours working autonomy. GEL version available.

### ADJUSTABLE FORKS



Universal ISO FEM 2A fork holder allows a manual and easy fork adjustment to carry any kind of load, pallet or skid.

### ADJUSTABLE BASE LEGS



Adjustable base legs to fit with various pallet sizes and aisle widths. With its superior versatility and extreme durability, it is the ideal solution for any indoor application.

### FORKOVER DESIGN



### FREE LIFT



# Duplex Mast - Electric Stackers

					GX - DUPLEX MAST ELECTRIC STACKER	
DESCRIPTION	1.2	MODEL			GX12/35 EVO	GX12/35 EVO STRADDLE
	1.3	DRIVE			ELECTRIC	ELECTRIC
	1.5	LOAD CAPACITY	Q	lb	2650	2650
	1.6	LOAD CENTRE DISTANCE	c	in	24	24
	1.8	LOAD DISTANCE, CENTRE DRIVE AXLE TO FORK	x	in	30.7	30.0
	1.9	WHEEL BASE	y	in	48.6	52.5
2.1	SERVICE WEIGHT		lb	1362.5	1649.1	
TYRES/CHASSIS	3.1	TIRES			Rubber + Poly/Poly	Rubber + Poly/Poly
	3.2	TIRE SIZE, FRONT (Ø x width)		in	9.8 x 3.0	9.8 x 3.0
	3.3	TIRE SIZE, REAR (Ø x width)		in	3.2 x 2.8	3.2 x 2.8
	3.5	WHEELS, NUMBER (x=DRIVEN) FRONT/REAR			1x+1/2	1x+1/2
	3.6	TREAD, FRONT	b10	in	22.2	22.2
	3.7	TREAD, REAR (MIN/MAX)	b11	in	16.1	42.6/54.6
DIMENSIONS	4.2	HEIGHT, MAST LOWERED	h1	in	88.6	88.6
	4.3	FREE LIFT	h2	in	3.1	3.1
	4.4	LIFT	h3	in	134.3	134.3
	4.5	HEIGHT, MAST EXTENDED	h4	in	154.2	154.2
	4.9	HEIGHT OF TILLER IN DRIVE POSITION (MIN/MAX)	h14	in	37.8/52.4	37.8/52.4
	4.15	HEIGHT, LOWERED	h13	in	3.5	1.4
	4.19	OVERALL LENGTH	l1	in	69.3	65.0
	4.20	LENGTH TO FACE OF FORKS	l2	in	24.0	25.6
	4.21	OVERALL WIDTH (FRONT/REAR MIN-MAX)	b1	in	31.5	31.5/47.2 59.2
	4.22	FORK DIMENSIONS	s/e/l	in	2.8/5.9/45.3	1.4/3.9/39.4
	4.25	DISTANCE BETWEEN FORK ARMS (MIN/MAX)	b5	in	22.0	9.1/31.1
4.26	DISTANCE BETWEEN FORK LEGS (MIN/MAX)	b4	in	-	38.0/50.0	
4.32	GROUND CLEARANCE, CENTRE OF WHEEL BASE	m2	in	0.8	0.8	
4.35	TURNING RADIUS	Wa	in	56.3	60.2	
PERFORMANCE DATA	5.1	TRAVEL SPEED, LADEN/UNLADEN		mph	2.9/3.2	2.9/3.2
	5.2	LIFT SPEED, LADEN/UNLADEN		ft/s	0.36/0.62	0.36/0.62
	5.3	LOWERING SPEED, LADEN/UNLADEN		ft/s	0.82/0.98	0.82/0.98
	5.8	MAX GRADEABILITY, LADEN/UNLADEN		%	5/10	5/10
ELECTRIC MOTOR	6.1	DRIVE MOTOR POWER		kW	0.7	0.7
	6.2	LIFT MOTOR POWER		kW	2.2	2.2
	6.4	BATTERY VOLTAGE, NOMINAL CAPACITY		V/Ah	24/118 (C5)	24/118 (C5)
	6.5	BATTERY WEIGHT		lb	172	172
	6.6	ENERGY CONSUMPTION ACC. TO VDI CYCLE		kWh/h	0.9	0.9
	8.4	SOUND LEVEL AT DRIVER'S EAR		dB(A)	62	62

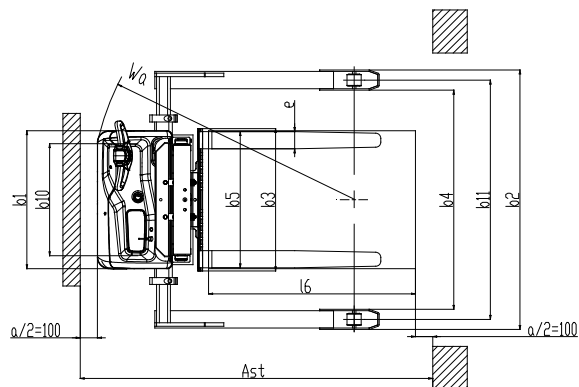
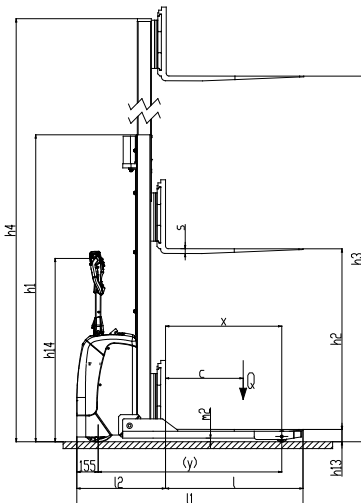

Distributed by



**POWERHANDLING, INC.**  
 1110 W RIVERSIDE AVE, STE 400 SPOKANE WA 99201  
 TEL: 509-244-8860 Fax: 509-267-6428 / sales@powerhandling.com / www.powerhandling.com